

Extending the CAN Bus



Application Sheet



Table of Contents

Table of Contents.....	- 2 -
1) Switching to 8C mode.....	- 3 -
2) Using I-CR module.....	- 3 -
2a) Extending the bus length.....	- 3 -
2b) "T" network configuration	- 4 -
2c) Connection of IG-MU and IG-IB units to a branched CAN bus.....	- 5 -
2d) Combination of two or more I-CR modules – in line network configuration.....	- 5 -
2e) Combination of two I-CR modules – complex segment solutions ("H" network configuration).....	- 6 -
2f) Combination of CAN bus and RS422 connection - inline network configuration with 3 segments	- 7 -
3) Bus-tie bridging mode.....	- 7 -
4) Peripheral CAN bus extension.....	- 8 -
5) Third party CAN nodes	- 8 -

With the call for more complex systems, the CAN bus is used on many sites to interconnect ComAp controllers. This allows to use some additional features of these controllers, like Power management, Var Sharing, and group local or remote monitoring.

For systems with many controllers in parallel, you may come to a stage, where the standard 200 meters length of the CAN bus is not sufficient. But you still have several possibilities to solve this problem. These are described in this Application sheet.

1) Switching to 8C mode

In recent versions of ComAp IG and IS controllers, there is a possibility to switch the CAN bus to slower speed, gaining the bigger distance of particular units. However, the total number of units in this case is limited to 8 pieces.

CAN bus mode = 32C:

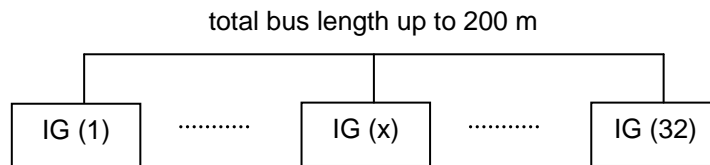

CAN bus mode = 8C:

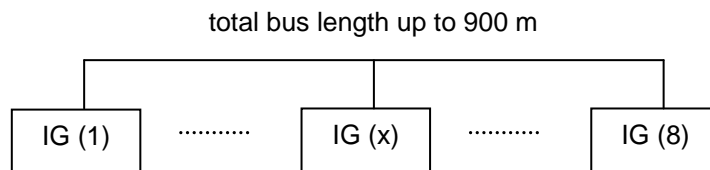

2) Using I-CR module

2a) Extending the bus length

Most typical case – you need to have “a bit” longer CAN bus than the limit is. Can be used in both CAN bus modes, and multiplies the total achievable distance by two.

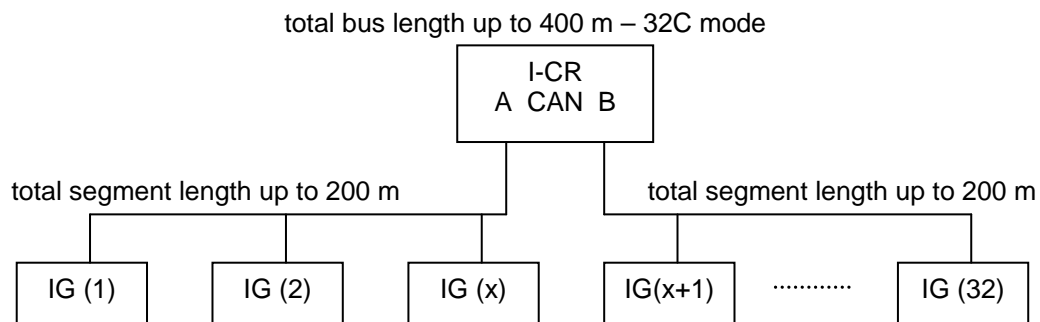

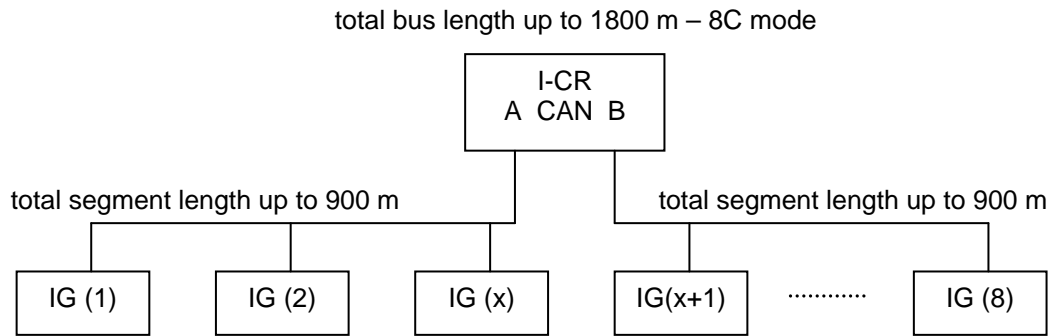

This is possible in unsymmetrical mode as well, e.g. if one segment is run in 32C mode, and the other in 8C mode. Useful with IntelliMains, as this controller may be placed in a substation, far-away from the others.

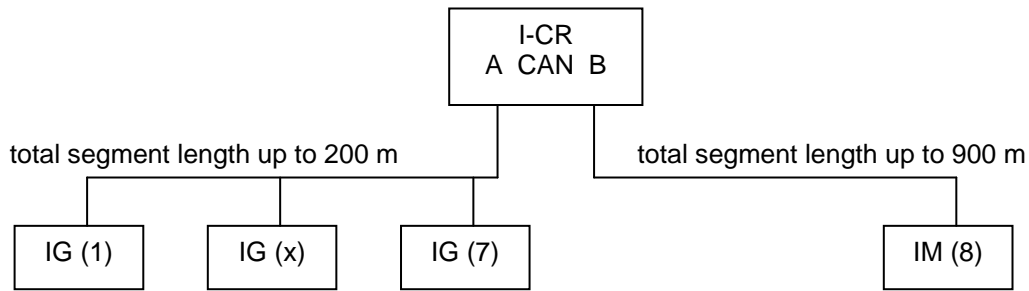

Note: If any segment in the network is run in 8C mode, the total number of controllers on the CAN bus is limited to 8!

2b) “T” network configuration

If you have all controllers on the CAN bus in-line, and need just a short branch of the bus. The “star” connection is normally not allowed with the CAN bus.

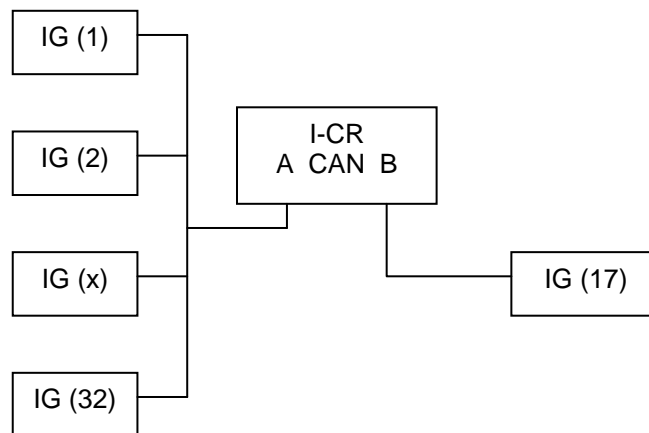

2c) Connection of IG-MU and IG-IB units to a branched CAN bus

It is possible to connect IG-MU and IG-IB units to any point of segmented CAN bus as normally (except of the “H” connection, see the chapter below).

However, we recommend to connect them (if possible) to the segment with the highest number of controllers, as the PC communication loads the CAN bus a lot.

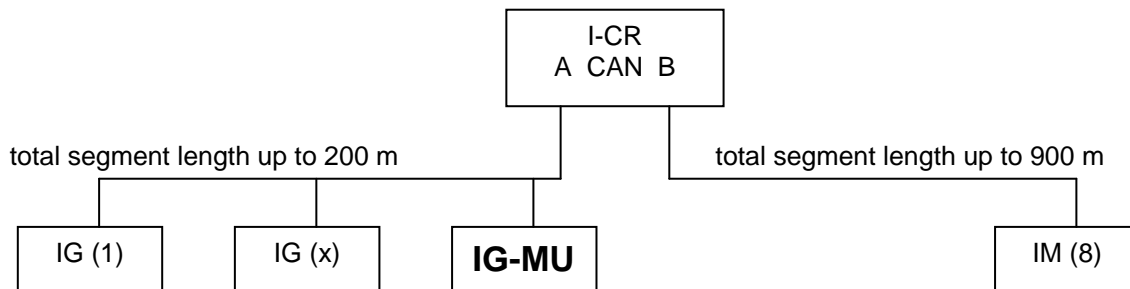

Sometimes it may be necessary to connect these units to an empty segment (e.g. units in engine room, and IG-MU with local RS-232 connection in distant monitoring room). In this case, you have to place a link on the jumper to force this segment to work in 32C mode (autodetection not possible because there are no IG/IS controllers present). In the example below (CAN B), it would be the jumper P3. For CAN A, it would be the jumper P2.

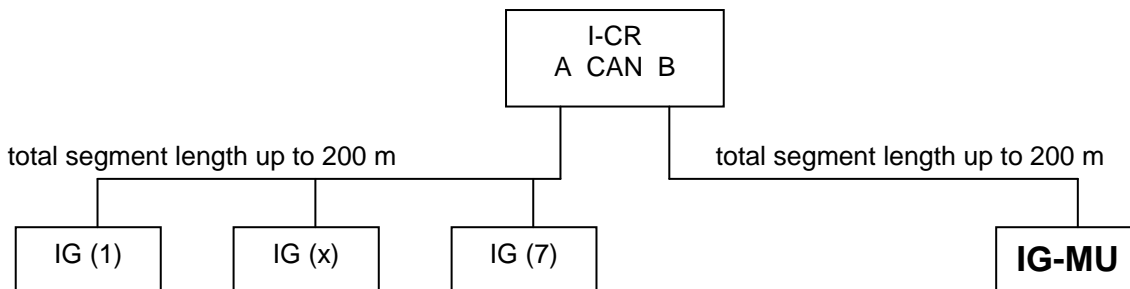

2d) Combination of two or more I-CR modules – in line network configuration

It is possible to connect more I-CR units on the CAN bus in order to extend it more. However, each bridge delays the system reaction, thus does not fully replace the direct wire connection. This is valid especially for PC communication, so the communication with a unit located in the opposite segment to where an IG-MU is connected could be much slower than with a unit located in the same segment like IG-MU.

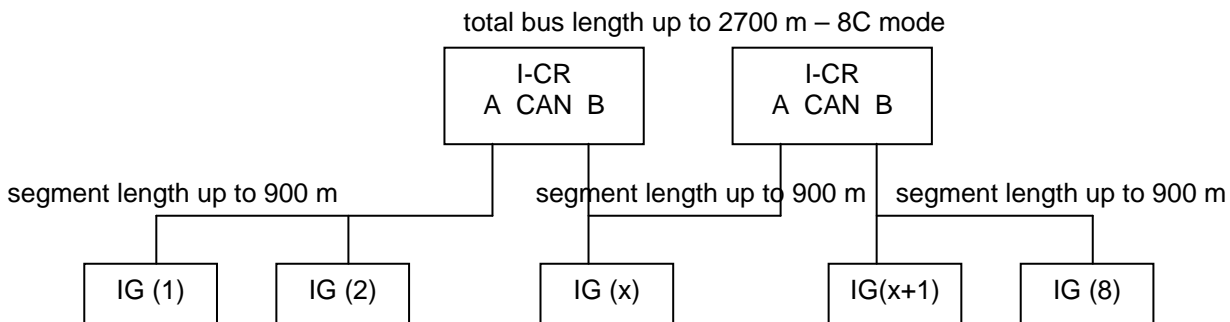

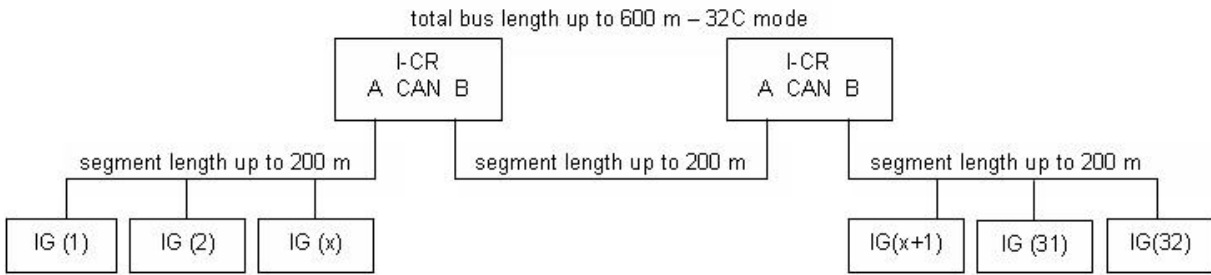

2e) Combination of two I-CR modules – complex segment solutions (“H” network configuration)

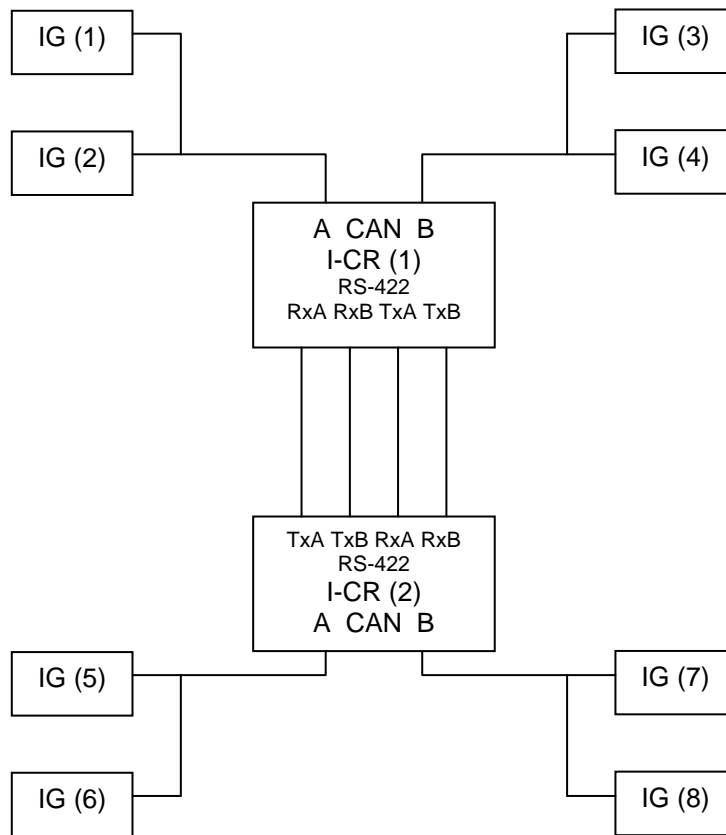

In the above configuration, the total CAN bus length (supposed all segments are run in 8C mode) is up to $4 \times 900 + 1200 = 4800 \text{ m}!$

In this case, the two I-CR units are interconnected via RS-422 line, which bridges up to 1200 m. The whole system behaves like one common CAN bus.

Suitable only for lower number of controllers, as the RS-422 line is not able to substitute accordingly the CAN bus capacity.

Notes:

- The maximum number of controllers in this mode is limited to 8!
- The I-CR UART port cannot be run in RS-485 mode.
- It is recommended (if possible) to split the connected controllers symmetrically to both I-CR units.
- IG-IB unit cannot be used to monitor the system in this mode. IG-MU can be used, but the connection is very slow.
- Jumper P10 – If “H” network configuration used, it must be switched to RS-422 mode.

2f) Combination of CAN bus and RS422 connection - inline network configuration with 3 segments

In the picture below there is a site drawing - 3 groups of controllers. If we use 4 pcs of I-CR (it means 2 couples), we can bridge up to 1 km with RS422 line between the particular buildings. So every I-CR module is connected at one side to the local CAN bus, the other I-CR CAN port is unused. The I-CR couples are interconnected via the RS422 line.

The RS422 line capacity is comparable to the slow CAN (~ 50 kbps), so it is not possible to serve substantially higher number than 8 controllers. Configuration with 8 controllers has been successfully tested and we cannot guarantee full functionality if more controllers are used.

Further limitations:

- It is definitely not possible to run remote communication via a system like this, i.e. no IG-IB, no I-LB could be used. Independent RS485 network has to be built. If you intend to use IS-NT, it is quite easy to interconnect their RS485(2) ports to manage it. Still there is a RS485 line length limitation ~ 1,2 km.
- Every shared output group SHBOUT transmitted over the system is equivalent to approx. 1/2 of a controller load. E.g. if you intend to transmit in total 4 binary groups, it is as if 2 next controllers were added into the system.
- If the system runs at 60Hz and not 50Hz, the limit for the max. number of controllers is adequately reduced.

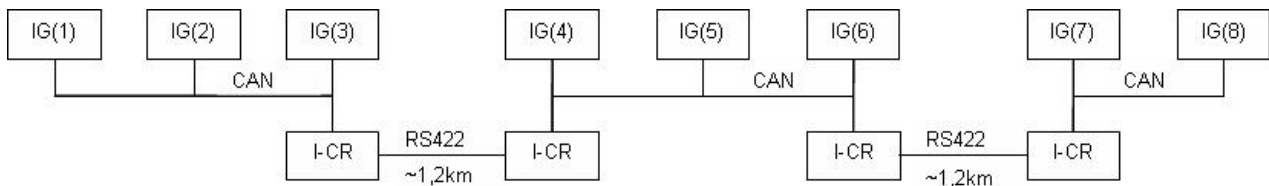

3) Bus-tie bridging mode

In applications with bus-tie breakers, it is normally necessary to break the CAN bus in the case that bus-tie breaker is open. This is to provide independent VAR-Sharing of separated segments. But at the same time this prevents the remote communication to monitor all controllers at once.

On the example below, the IG-MU can access only the controllers to the left. For remote monitoring of the controllers at the right side, it would be necessary to use another IG-MU, which brings yet another complications (not possible to display all units in MultiEdit etc.).

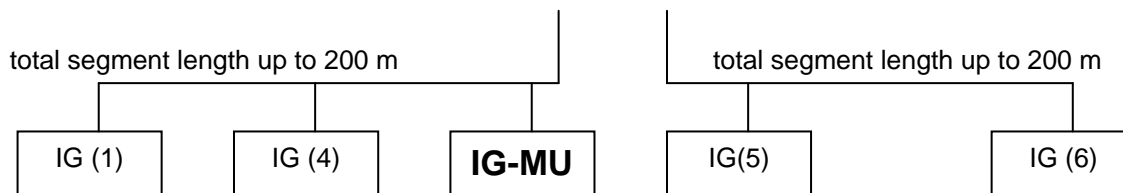

Linking jumper P4, you can activate the bus-tie bridging mode of I-CR.

The unit searches for the controller with CAN address 4, and monitors its binary input 9. It is supposed that the bus-tie breaker status (feedback) signal be connected to this input – this has to be provided externally.

If I-CR senses the bus-tie to be open, it makes the particular segments “invisible” one for another.

However, IG-MU (or IG-IB) communication can still pass through, thus remote monitoring of controllers 1-6 is still possible.

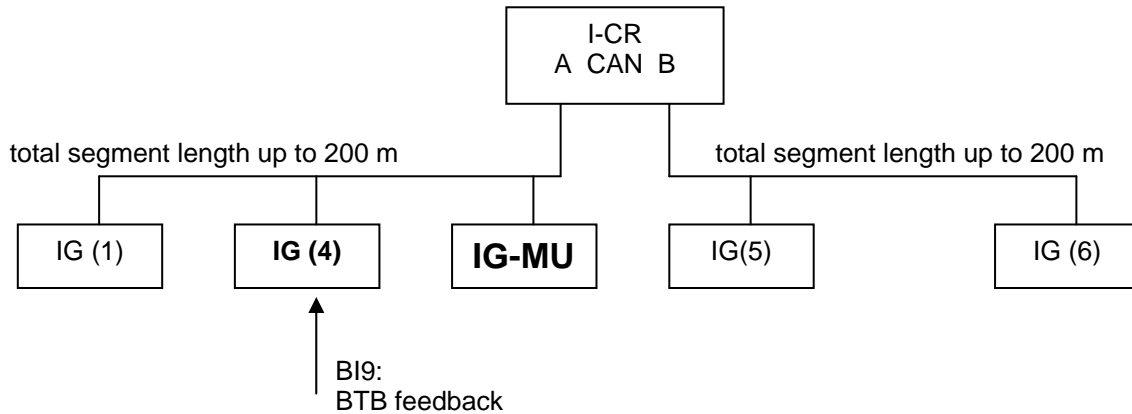

Notes:

- The system will not work, if there are no controllers present on both sides of the I-CR unit. I.e., even if the BTB information is read from the controller in CAN bus branch A, there must be at least one communicating controller in branch B!
- For more complex systems with two bus-tie breakers, it is possible to use another I-CR and read it's bus-tie status info from controller with address 3. On that secondary I-CR unit, jumper P5 must be linked.
- Controller with address 4 (or 3 with P5 linked) always has to be connected to CAN A port!
- LS line is independent on this system, thus must be interrupted as normally using a relay, if BTB is open.
- If only IS controllers are used, the bus-tie status information is read from binary input 16 of IS-CU.
- RS-422 connection of two I-CR units is not supported in this mode ("H" CAN bus network configuration).
- The information read from controllers is not related to their configuration, i.e. no signal polarity is considered (normal / inverted). Read logical 1 is always interpreted as "bus-tie closed" and 0 as "bus-tie opened".

4) Peripheral CAN bus extension

It is possible to use I-CR for peripheral CAN bus extension as well. All standard ComAp units can be used (IG-IOM, IGS-PTM, IS-AIN8, IS-BIN16/8, IGL-RA15, I-CB/xx).

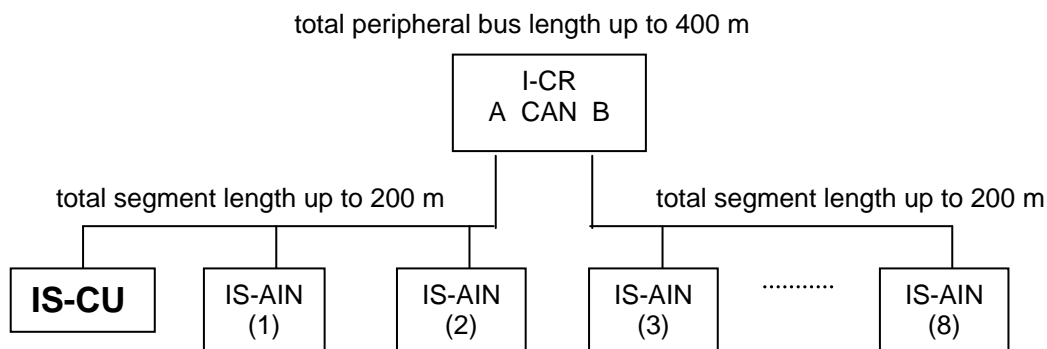

5) Third party CAN nodes

Third party CAN nodes can be used, but must fulfil the following conditions:

- Work at either of the following CAN bus speeds – 50 / 125 / 250 kbps
- Send at least one CAN message within every two seconds
- Use only standard frames. No remote request frames will pass through I-CR.

Note: In general, all J1939 compatible ECUs fulfil these requirements.