



**R.A. Electronic Group**

Introducing New Generation Technology

# AUTO MAINS FAILURE MODULE

MODEL: AMF-50

## INSTRUCTIONS IN BRIEF

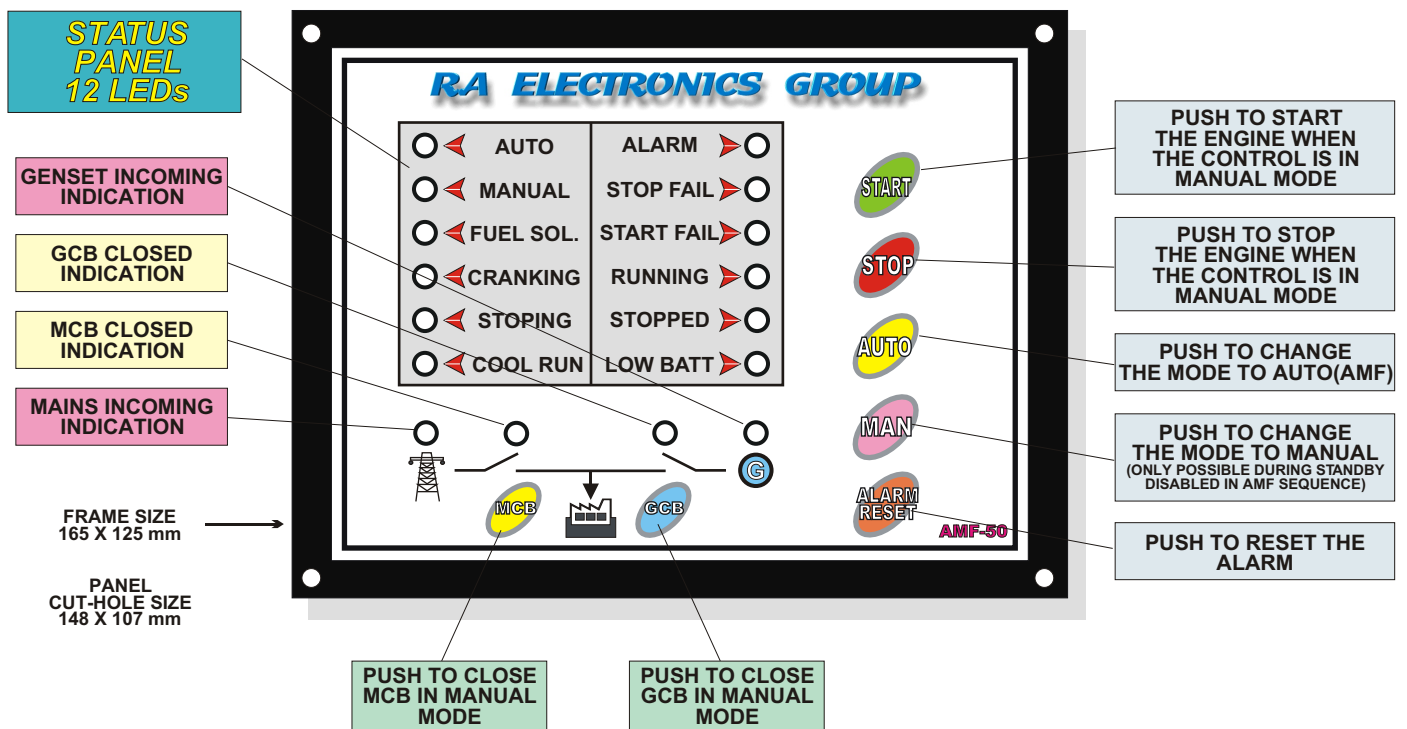

### FEATURES

- INTEGRATED MICROPROCESSOR BASED SYSTEM
- AUTO / MANUAL START/STOP OF THE GENSET
- TOUCH KEY PAD WITH ICONS
- 12 LEDs STATUS PANEL
- MAINS VOLTAGE DROP SENSING (AVERAGE OF 3 P)
- MAINS & GENSET INCOMING INDICATION
- MAINS & GENSET CIRCUIT BREAKER STATUS INDICATION
- ENGINE SAFETIES INDICATIONS
- MANUAL LOAD CHANGEOVER B/W MAINS & GENSET
- GENERATOR C.B & MAINS C.B CONTROLS
- BATTERY VOLTAGE MONITOR
- EMERGENCY SHUTDOWN INPUT (OPTIONAL)
- MANUAL CHANGEOVER WITH KEYS
- ALARM RESET



